

INDAR CIM  
COGENERATION, INDUSTRY AND MARINE



M A R I N E



**Indar**



Indar Electric, an Ingeteam company, has worked for over sixty years in the design, manufacture and supply of electrical rotating machines.

# C U S T O M D E S I G N E D

R E S E A R C H , D E V E L O P M E N T A N D I N N O V A T I O N

The experience acquired over the years has enabled us to produce a wide range of products using in-house technology and to assume a leadership position in both the Spanish and international markets.

The electric motors and generators we have installed worldwide are the best examples of our competitiveness and production capacity.

One of the most important features of Indar Electric is the quality we offer in our products and services, backed up by ISO 9001 and 14001 certification, and the high level of involvement of all the personnel who directly and indirectly take part in the design and manufacture processes.

Ingeteam has made a firm commitment to the EFQM model as a competitive framework for the years to come, with the aim of offering excellence in our products and services.

The technical department of the Indar CIM Marine business unit and the R+D+i support unit are staffed by highly qualified personnel and are equipped with the most advanced computer resources for the design and development of the motors and generators.

The calculation programs used in their design are based in advanced electromagnetic and mechanical simulation tools (mechanical finite elements, electromagnetic flows and fluid dynamics simulations).

It also works closely with technology centres and universities in the search for new products.



Electromagnetic design

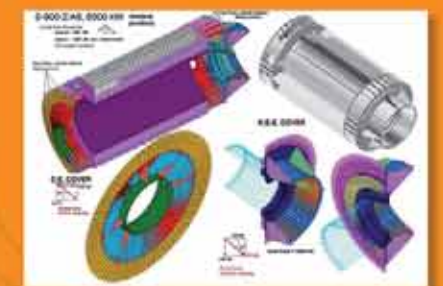

Finite elements design

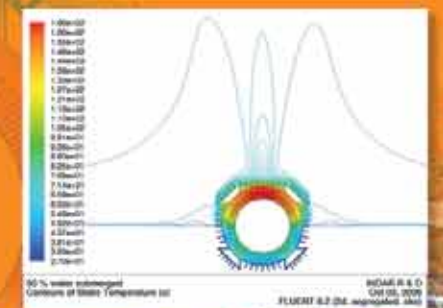

Thermal design

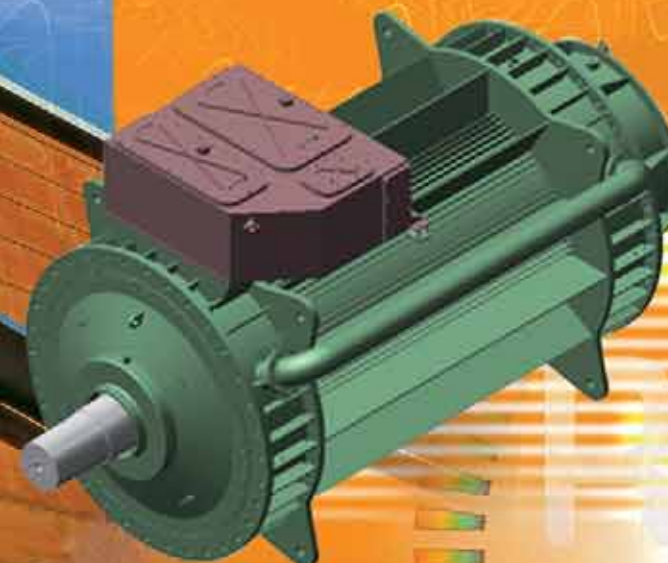

3D Design

Cooperation with the customer is part of the company's philosophy, with personal treatment and attention as the basis for the relationship and a key joint objective:

**To develop products and services that adapt to the characteristics of each project.**





A W I D E R A N G E O F P R O D U C T S F O R E L E C T R I C D R I V E S

existing aboard ship, namely main and transverse electric propulsion, principal and auxiliary power generation, deck machinery, etc.

- For more than 50 years, the shipbuilding industry has been trying and testing the sturdiness of Indar machines and, over that period of time, Indar Electric has won recognition and prestige for the reliability of its machines in the most adverse working conditions.
- Such long experience in the supply of equipment for all kinds of craft, e.g. fishing ships, offshore ships, cargo liners, dredges, ferries, etc., proves the users' trust in our machines.
- The modular design of this series makes them easily adaptable to the requirements of our clients, allowing us to supply highly-reliable and easily-maintainable motors and generators.

**2 HOPPER DREDGERS 11,300 m<sup>3</sup>  
Jan De Nul (Belgium)**

**Technical data of the ship** - Length Overall: 142.46 m.  
Beam: 27.5 m. Length between perpendiculars: 127 m.  
Draught: 9 m. Hopper capacity: 11,300 m<sup>3</sup>.  
Propulsion: 2x5,760 kW. Speed: 15 knots.

Indar Electric has supplied the following machines:



Synchronous generators,  
for electric needs

**6,750 kVA**

1,200 rpm, 6.6 kV  
2 main generators,  
per vessel



**2 HOPPER DREDGERS capacity 4,400 m<sup>3</sup>  
Jan De Nul (Belgium)**

**Technical data of the ship** - Length Overall of 94.7 m.  
Beam: 22 m. Length between perpendiculars: 84 m. Draught: 8.5 m.  
In side diameter suction pipes: 900 mm. Dredging depth: 25 m

Indar Electric has supplied the following machines:

- **1 Auxiliary generator**  
625 kVA, 1,500 rpm, 690 V
- **1 Bow thruster motor**  
550 kW, 1,100 rpm, 690 V
- **2 Propulsion motors**  
2,150 kW, 1,000/1,200 rpm, 3.3 kV
- **1 Pump motor**  
3,000 kW, 1,200 rpm, 690 V
- **1 Pump motor**  
1,200 kW, 1,000 rpm, 690 V
- **2 Main generators**  
3,375 kVA, 1,000 rpm, 690 V



Asynchronous motors,  
Diesel Electric propulsion

**2,150 kW**

1,100 rpm, 690 V  
2 propulsion motors, per vessel



Asynchronous motor, to drive  
the discharge pump to the land

**7,500 kW**

1,200 rpm, 3.3 kV  
1 dredger pump motor, per vessel



Synchronous generators,  
Diesel Electric propulsion

**3,375 kVA**

1,000 rpm, 690 V  
2 main generators, per vessel



Submersible motor

**3,400 kW**

280/320 rpm, 3.3 kV  
1 submersible motor





SUMERSIBLES, DC AND ASYNCHRONOUS MOTORS

Indar Electric is a world leader in this line of hi-tech equipment.

— **Submersible motors** with power from 1,000 kW up to 10,000 kW and voltage from 690 V up to 15 kV, used as direct or indirect pump drives in dredgers and cutters. Degree of protection IP68 (the design of the cover, connection box and bearing box is of fundamental importance). Different types of cooling (oil, water or air). Submersible up to a depth of 1,000 m.

— **Asynchronous motors** with power from 400 kW up to 15,000 kW and voltage from 690 V up to 15 kV. Horizontal or vertical. Different degrees of protection and refrigeration. Direct power supply or with converters. Application in: main electrical propulsion and bow thrusters; pump drives; deck machinery, etc.

— **DC motors** with power from 400 kW up to 4,000 kW. Extremely precise speed regulation. For fishing machinery, propulsion with low noise emission (especially designed for oceanographic vessels).

— **International standards** such as CEI, NEMA, VDE and the special requirements of main certifying bodies such as BV, LR, DNV, GL, RINA, etc.

**SWATH FERRIES  
Holland**

Fed by PWM for SWATH ferries line Vlissingen – Breskens in Holland. Built by Damen Shipyard. Supply of two AC, low speed double propulsion motors, with double stator and rotor in same housing. They are designed to guarantee the operation in extreme weather and sea conditions for which it has been necessary to develop an innovative tailor made diesel electric propulsion package based upon two generators driving double propulsion motors.



1,320 kW

353 rpm, 3 x 690 V  
2 double AC motors



SERIES  
→ **MTK** up to 8,000 kW



**HOPPER DREDGER VASCO DA GAMA  
Jan De Nul (Belgium)**

Indar Electric has supplied the biggest submersible motor in the world for this ship.

6,500 kW

253 rpm, 3.1 kV  
2 submersible motors

**OCEANOGRAPHIC RESEARCH VESSEL  
Vizconde de Eza (Spain)**

Oceanographic research vessel built for the Spanish Government (Ministry of Fisheries & Agriculture). Supply of AC synchronous motors fed by PWM drivers for main propulsion. High efficiency at low speed.



900 kW

0/160/180 rpm, 690 V  
2 AC motors 18 Hz





SUMERSIBLES, DC AND ASYNCHRONOUS MOTORS



**MIGUEL OLIVER RESEARCH VESSEL**  
 Spanish Fishing Directorate  
 Low noise diesel electric propulsion

**Technical data of the ship** - Total length: 70 m. Máx. speed: 14 knots. Bread: 14,40 m. Electric consumption: 3 MW. Load draught: 4,50. Gross tonnage: 2,480 GT. Delivered: 2007

One of the world's most advances fisheries and oceanographic research ships recently entered service with the Spanish Fishing Directorate. The propulsion has been designed and manufactured fulfilling the ICES 209 Standards as the noise transmission and water vibrations is concerned.

DC machines have long been the best solution for low noise operation. Indar motors were designed and built to meet the strictest ICES noise.

Thanks to the AFE (Active Front End) technology implemented for this project, no perturbations are produced in the 400 Vac, 50 Hz network. It this technology is specially suitable whenever there coexist under the same network, such as: navigation systems, oceanographic research, etc.

Indar Electric has supplied the following machines:

- **4 AC Generators**  
1,430 kVA, 1,500 rpm, 690 V
- **Propulsión power**  
2,000 kW
- **2 Super quiet DC motors**  
1,000 kW, 178 rpm, for main propulsion, 710 V



**TRAILING SUCTION HOPPER DREDGER 46,000 m³**  
 Cristobal Colon / Leiv Eiriksson (JDN)

**Technical data of the ship** - Hopper Capacity: 46,000 m³. Deadweight: 78,000 ton. Length overall: 223.0 m. Breadth: 41.0 m. Pump power (Trailing): 2 x 6,500 kW. Pump power (discharging):16,000 kW. Maximum dredging depth: 155,0 m.

These two ultra-large trailer hopper dredgers, which at capacity of 46,000 m³ is the largest of their type in the world.

Indar Electric has supplied the following machines:

- **2 Main generators**  
18,5 MVA, 1,200 rpm, 6.6 kV
- **2 Jet pumps**  
2,150 kW, 0-1,000 rpm, 3.3 kV
- **2 Submersible motor**  
6,500 kW, 0-253 rpm, 3.3 kV
- **3 Tunnel thruster motor**  
2,150 kW, 1,200 rpm, 6.6 kV
- **2 Shore discharging pumps motors**  
8,000 kW, 0-1,000 rpm, 3.3 kV

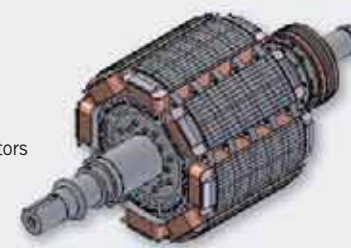
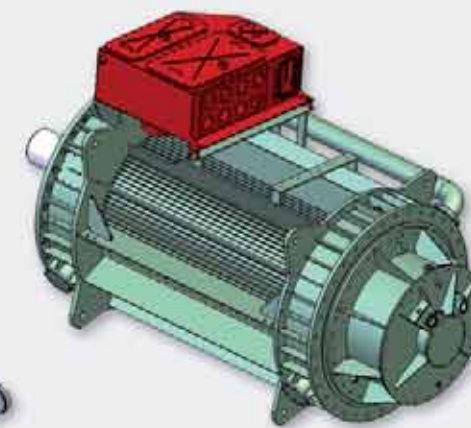
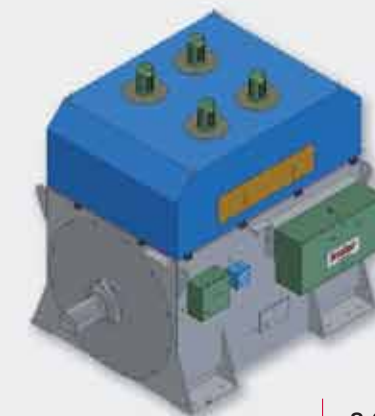

**8,000 kW**

0-1,000 rpm, 3.3 kV  
2 discharge shore pump motors

**6,500 kW**

253/325 rpm, 3.3 kV  
2 submersible motors

**18,500 kVA**

900 rpm  
2 main generators





H I G H L Y - R E L I A B L E C O M P A C T S Y N C H R O N O U S G E N E R A T O R S

Given the modular design of our generators we are able to supply standard generators, adapted to the specific needs of our customer, and deliver them within a minimum period of time.

**OCEANOGRAPHIC RESEARCH VESSEL  
Celtic Explorer (Ireland)**

Built for the Irish Marine Institute by Damen Shipyards in cooperation with Bakker Slidrecht. Specially designed "low noise an low vibration" generators and motors using the most advanced software to calculate all Mechanical Finite Elements variations.



2 off main generators

1,875 kVA

1,000 rpm, 690 V  
2 synchronous generators

2 off low speed and low noise diesel electric DC propulsion motors in tandem execution

1,500 kW

215 rpm, 750 V  
2 DC motors

**CUTTER DREDGER  
Jan De Nul (Belgium)**

Indar Electric has taken active part in the newbuild project of the world's largest self propulsion cutter suction dredger supplying the main driving and electric power generation systems as well as Diesel Electric propulsion motors.

Indar Electric has been committed to supply the Dredge Booster pump motors, each with a capacity of 6,000 kW, a 3,800 kW submersible dredge pump e-motor as well as 2 x 3,800 kW Diesel Electric propulsion motors and a number of winch motors on board.

All motors and generators have been specifically designed to work under extreme sea condition sand comply with the European standard IEC and are certified by Bureau Veritas.



10,250 kVA

200 rpm, 6.6 kV  
3 main generators



Indar Electric has supplied the following machines:

- 2 Ladder winch motors  
900 kW, 1,200/1,600 rpm, 690 V
- 2 Cutter motors  
3,800 kW, 1,000/1,200 rpm, 3.3 kV
- 2 Spud winch motors  
575 kW, 0/750 rpm, 440 V
- 1 Submerged dredge pump  
3,800 kW, 1,000/1,200 rpm, 3.3 kV
- 2 Propulsion motors  
3,800 kW, 1,000/1,200 rpm, 3.3 V
- 3 Main generators  
10,250 kVA, 200 rpm, 6.6 kV
- 2 in board dredge pump motors  
6.000 kW, 0/1,000/1,200 rpm, 3.3 kV
- 3 Hydraulic pump motors  
400 kW, 1,800 rpm, 6.6 kV
- 2 Side winch motors  
575 kW, 0/750 rpm, 440 V
- 1 Auxiliary generator  
2,250 kVA, 1,000 rpm, 440 V



3,800 kW

1,000/1,200 rpm, 3.3 kV  
2 propulsion motors

- Synchronous generators with power from 1.250 kVA up to 35.000 kVA and voltage from 690 V up to 15 kV.
- Can be coupled to any type of motor (diesel, fuel, gas, oil).
- High capacity for withstanding overloads and vibrations caused by the drive.
- High-performance.
- Mechanical configuration, degree of protection, and type of cooling studied in each case according to clients specifications.
- International standards such as CEI, NEMA, VDE and the special requirements of main certifying bodies such as BV, LR, DNV, GL, RINA, etc.



SERIES  
→ BZK up to 15,000 kW





HIGHLY - RELIABLE COMPACT SYNCHRONOUS GENERATORS



**SELF PROPELLED - CUTTER SUCTION DREDGER**  
**IBN Battuta, Zheng He & JDN-8066 JDN**

**Technical data of the ship** - Length Overall of 138.5 m.  
Total installed diesel engine power: 23,520 kW. Breadth: 26.0 m.  
Speed: 13 kn. Draught: 5.5 m. Dredging depth: 35.0 m

Dredging and Maritime Management S.A. has built in Uljanik Brodogradiliste d.d. in Pula, Croatia, three large self-propelled cutter suction dredgers.

These vessels are further developments of the self-propelled cutter dredger Leonardo Da vinci, incorporating at the same time the experience and technical innovations of the J.F.J. De Nul, the largest and most powerful cutter dredger in the world.

Indar Electric has supplied the following machines:

- **3 Main generators**  
7,778 kVA, 1,200 rpm, 6.6 kV
- **4 Propulsion and cutters motors**  
3,500 kW, 0-1,000 rpm, 3.1 kV
- **3 Dredger pumps**  
5,000 kW, 0-1,000 rpm, 3.1 kV

**OFFSHORE SUPPORT VESSEL**  
**M/V Adams Challenge**

The vessel is a dynamically positioned diesel electric powered, multi role offshore support vessel with rapid and efficient handling characteristics, capable of supporting a wide range of offshore activities, including diving support, ROV support, survey support, cable lay and offshore construction and maintenance.

The vessel is equipped with a dual redundant dynamic positioning system configured to and suitable for the support activities, is designed for a speed of 15 knots in a fully loaded condition under trials conditions with the electric motors operating at 100% power.

Propulsion is provided by twin azimuth propeller units aft, each driven by an electric motor (2,200 kW). Transverse thrust is provided by then twin azimuth units aft and by three transverse thrusters forward, one of which is a retractable azimuth unit (three electrical motors 800 kW each motor).



Indar Electric has supplied the following machines:

- **4 generators**  
2,312 kVA, 720 rpm, 690 V
- **2 Main propulsion motors**  
2,450 kW, 900 rpm, 690 V
- **3 Tunnel thrusters motors**  
2x 990 kW, 1,200 rpm, 690 V  
1x1,000 kW, 1,800 rpm, 690 V

**SEAWAY HEAVY LIFTING**  
**HLV 5000 - Oleg Strashnov**

For this innovative heavy lifting vessel for Seaway Heavy Lifting, built at IHC Merwede Krimpen Shipyard, we developed the electrical machines for diesel-electric propulsion concept, featuring a redundant energy generation and propulsion system.

The thruster motors are fed and controlled by direct water-cooled frequency converters. Together with the vessels management DP system (DP3 notation) this enables an optimisation of the availability.

The vessel will enable her to have a transit speed of 14 knots, combined with exceptional working characteristics for a monohull design. Lift heights of 100 m for the 5,000 mt main hook and 132 m for the 800 mt auxiliary hook enables the vessel to undertake an impressive range of projects from dual hook upending of large jackets to heavy deck installations.



Indar Electric has supplied the following machines:

- **6 Main generators**  
4,500 kW, 750 rpm, 6.6 kV
- **2 Propulsion thrusters motors**  
5,000 kW, 500 rpm, 3.1 kV
- **2 DP thrusters motors**  
3,500 kW, 500 rpm, 3.1 kV
- **2 Tunnel thrusters motors**  
1,150 kW, 1,000 rpm, 660 V

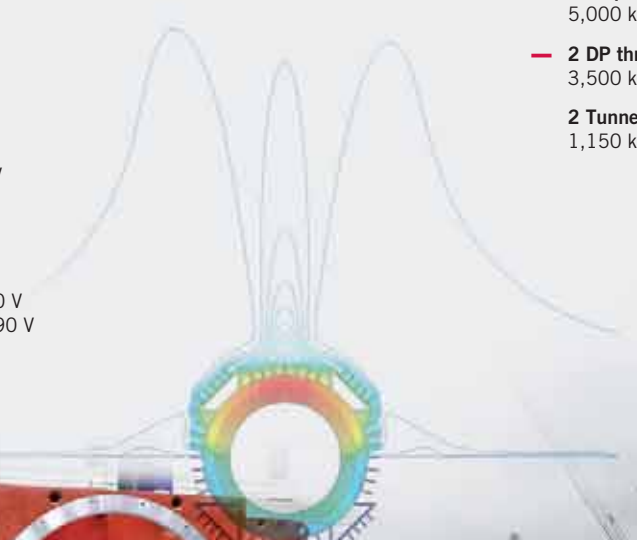



## TECHNICAL ASSISTANCE AND REPAIR SERVICES

Technical Assistance Services, repairs and spare parts and customized maintenance plans.



Indar Electric has supplied the following machines:

- **3 asynchronous motors**  
2,950 kW for azimuthing nozzles fitted afterwards.
- **2 asynchronous motors**  
2,400 kW fed by PWM for azimuth thruster fitted in the forward part.
- **1 asynchronous motor**  
2,200 kW for transverse thruster arranged in a tunnel forward.

### REELED RIGID PIPE LYING OFFSHORE CONSTRUCTION VESSEL Subsea 7

The vessel is fully Dynamic Positioned (DP II), suitable for world-wide operation of reeled rigid pipe laying and offshore construction work.

It has an electric propulsion system consisting of 3x2,950 kW fixed pitch propellers in azimuthing nozzles aft. Two 2,400 kW retractable Azimuth thrusters are fitted in the forward part of the vessel; one 2,200 kW transverse thruster is arranged in a tunnel forward.

This flexible pipelay/offshore construction vessel, with a lifting capacity of 400 t and a storage capacity for flexible pipes carried by two 1,250 t carrouseles belowdecks and by a 3,000 t carrousel on deck, is able of accurately positioning and anchoring pipes up to depths of 3 kms.



**Asynchronous motor**  
**2,400 kW**  
900 rpm, 660 V  
2 asynchronous motors



### DOUBLE ENDED FERRY Dokter Wagemakeer (Holland)

For the MV/DOKTER WAGEMAKEER, a double ended ferry for the owners TESO, which is deployed on the route Den Helder – Texel in Holland and built at Damen Shipyards, redundant Diesel Electric propulsion and energy concept has been designed.

The main system power the Indar 2x2 Diesel Electric thrusters forward and aft motors of 1,650 kW each, which can be coupled and operate as one or be split into two independent half systems. An electric propulsion system that guarantees supply and power even under the most extreme circumstances to the thrusters.

Asynchronous motors fed by PWM

**1,650 kW**  
900 rpm, 660 V  
4 main motors

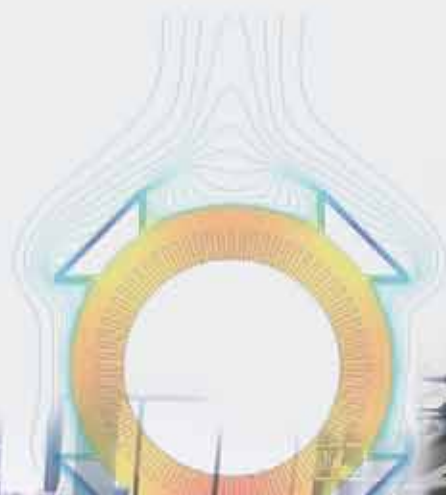

- Our service, together with our workshop network allows us to offer an effective and agile service.
- The initial analysis made during the commissioning of our machinery allows us to develop **personalised maintenance programmes**. This involves both preventative and predictive maintenance.
- Through our spare parts service, we establish **calendars and specific initiatives in close coordination with our assistance team**. Manufacturing and supplying our own spare parts as well as third-party ones also forms part of our **Customer Support Service**.
- Common elements that form part of our service include sets of rings and coils, complete rotors, spare stators, DC poles, shafts, etc.
- Our **extensive test bench facilities**, together with the support from our machine engineering department, enables us to solve complex problems and guarantee our repairs.
- Our support team has **experience in a wide range of fields of application** (marine, hydraulic, cogeneration, etc.) and in all types of mechanical and electrical contingencies.



***Indar***

Una Marca ***Ingeteam***